

2 Flutes Eco Cut Short Length Ball End Mills For Multi Purpose.

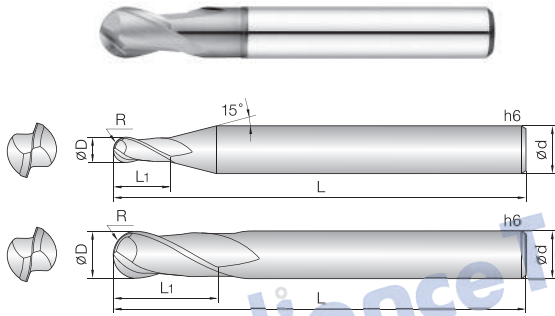

2ESB

- Ball Endmills for various work materials (HRC~50) Carbon steels, Mould steels, Pre-hardened steels
- Optimum for various work materials by E coating.
- High-Precise edge tolerance.
- Good surface finish.
- Short overall length for easy use with shrinking chuck.
- Minimize fracturing by high TRS fine(0.5µm) WC grade.



Unit(mm)

Model Number	Cutting Dia. D	Radius Of BN R	Length Of Cut L1	Effective Length L2	Overall Length L	Shank dia d
2ESB 005 005 440	0.5	0.25R	0.5	-	45	4
2ESB 006 006 445	0.6	0.3R	0.6	-	45	4
2ESB 007 007 445	0.7	0.35R	0.7	-	45	4
2ESB 008 008 445	0.8	0.4R	0.8	-	45	4
2ESB 009 009 445	0.9	0.45R	0.9	-	45	4
2ESB 010 010 445	1	0.5R	1	-	45	4
2ESB 010 010 650	1	0.5R	1	-	50	6
2ESB 012 012 445	1.2	0.6R	1.2	-	45	4
2ESB 015 015 445	1.5	0.75R	1.5	-	45	4
2ESB 015 015 650	1.5	0.75R	1.5	-	50	6
2ESB 020 020 445	2	1R	2	-	45	4
2ESB 020 020 650	2	1R	2	-	50	6
2ESB 030 030 445	3	1.5R	3	-	45	4
2ESB 030 030 650	3	1.5R	3	-	50	6
2ESB 040 040 445	4	2R	4	-	45	4
2ESB 040 040 650	4	2R	4	-	50	6
2ESB 050 050 650	5	2.5R	5	-	50	6
2ESB 060 060 650	6	3R	6	-	50	6
2ESB 060 060 660	6	3R	6	-	60	6
2ESB 080 080 850	8	4R	8	-	50	8
2ESB 080 080 860	8	4R	8	-	60	8
2ESB 100 100 A60	10	5R	10	-	60	10
2ESB 100 100 A75	10	5R	10	-	75	10
2ESB 120 120 C60	12	6R	12	-	60	12
2ESB 120 120 C75	12	6R	12	-	75	12