

## 4 Flutes Hard Cut Spherical 3D Cut 270° Ball End Mills For Hardened Steels

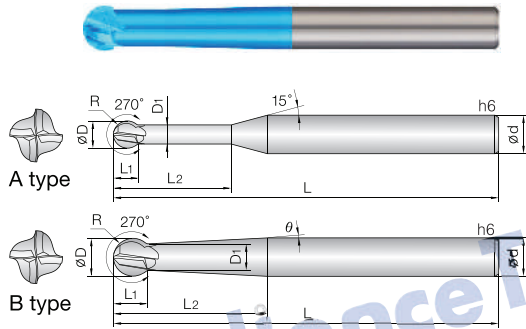

# 4HSHB

- **Ball Endmills for various work materials (HRC 52-68) Pre-hardened steels and Hardened steels.**
- Good wear resistance by high quality Si-based H coating.
- High-Precise edge tolerance.
- 270° degree Ball shape for wide range 3D machining.
- Minimize chattering and fracturing by taper designed flute.
- Good surface finish.
- Outstanding performance at high speed machining by ultra fine (0.2µm) WC grade.



Unit(mm)									
Model Number	Cutting Dia. D	Radius Of BN R	Neck Dia D	Length Of Cut L1	Effective Length L2	Angle θ	Type	Overall Length L	Shank dia d
4HSHB 010 000 040 660	1	0.5R	0.7	0.8	4	0°	A	60	6
4HSHB 010 000 060 660	1	0.5R	0.7	0.8	6	0°	A	60	6
4HSHB 010 013 200 675	1	0.5R	0.7	0.8	20	1°30'	B	75	6
4HSHB 015 000 060 660	1.5	0.75R	1	1.2	6	0°	A	60	6
4HSHB 015 000 080 660	1.5	0.75R	1	1.2	8	0°	A	60	6
4HSHB 015 013 200 675	1.5	0.75R	1	1.2	20	1°30'	B	75	6
4HSHB 020 000 060 660	2	1R	1.4	1.7	6	0°	A	60	6
4HSHB 020 000 100 660	2	1R	1.4	1.7	10	0°	A	60	6
4HSHB 020 013 200 675	2	1R	1.4	1.7	20	1°30'	B	75	6
4HSHB 030 000 100 660	3	1.5R	2.1	2.5	10	0°	A	60	6
4HSHB 030 000 150 660	3	1.5R	2.1	2.5	15	0°	A	60	6
4HSHB 030 013 300 675	3	1.5R	2.1	2.5	30	1°30'	B	75	6
4HSHB 040 000 120 660	4	2R	2.8	3.4	12	0°	A	60	6
4HSHB 040 000 200 660	4	2R	2.8	3.4	20	0°	A	60	6
4HSHB 040 030 250 675	4	2R	2.8	3.4	25	3°	B	75	6
4HSHB 050 010 400 6A0	5	2.5R	3.5	4.2	40	1°	B	100	6
4HSHB 060 000 150 6A0	6	3R	4.2	5.1	15	0°	A	100	6
4HSHB 060 000 300 6A0	6	3R	4.2	5.1	30	0°	A	100	6
4HSHB 060 010 210 6A0	6	3R	4.2	5.1	21	1°	B	100	6
4HSHB 080 010 280 8A0	8	4R	5.6	6.8	28	1°	B	100	8
4HSHB 100 010 350 AA0	10	5R	7	8.5	35	1°	B	100	10
4HSHB 120 010 420 CC0	12	6R	8.5	10.0	42	1°	B	120	12

ECO-CUT

WIDE-CUT

HARD-CUT

ALU-CUT

D-CUT

SUS CUT

MAGIC DRILLS